

Mastercam®

LATHE

Mastercam Lathe lets you move the same part file between milling and turning operations with ease and confidence.

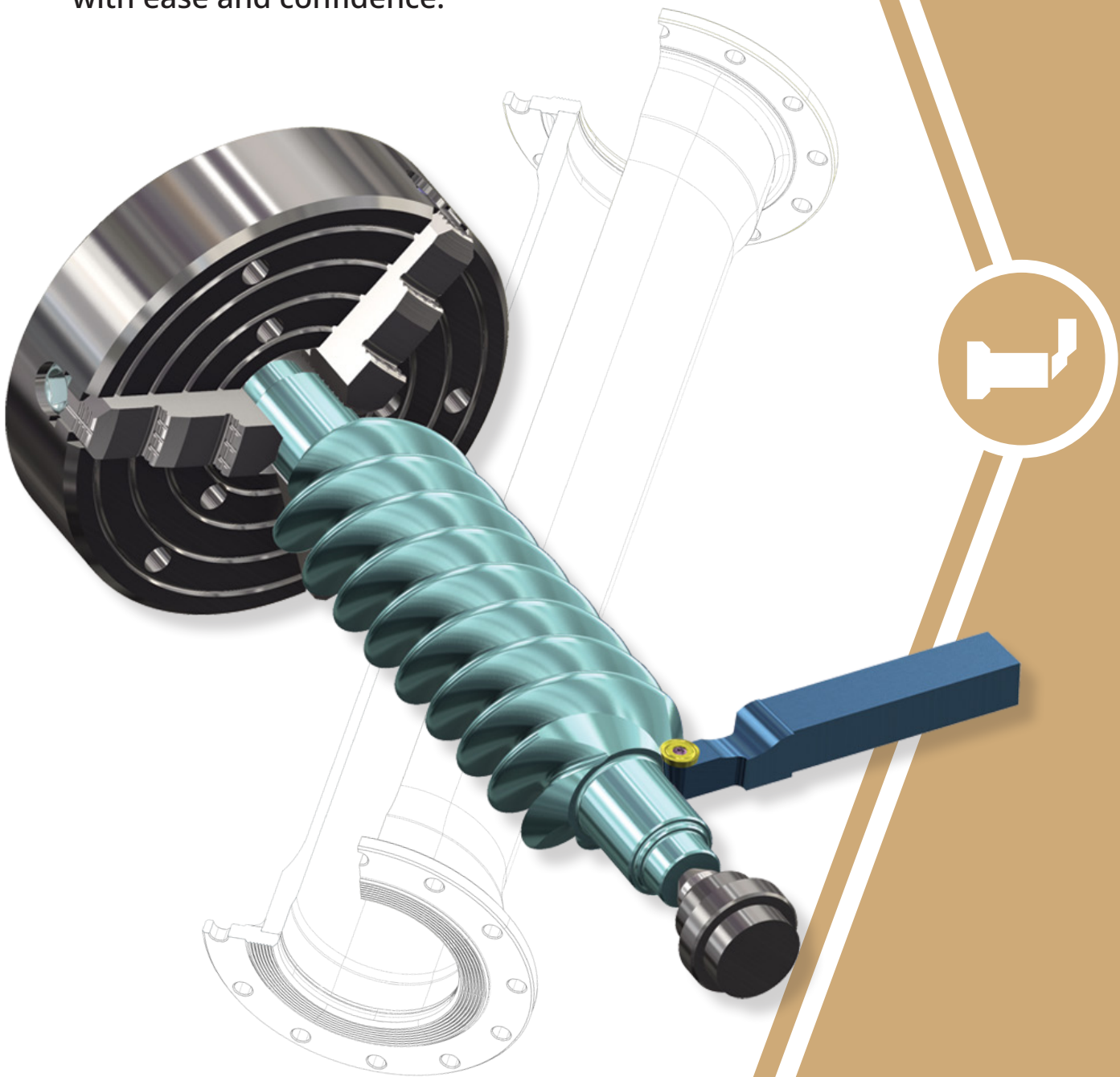

POWERFUL, FLEXIBLE TOOLS FOR TURNING

A set of tools that streamline your entire process.

From importing CAD files to Dynamic roughing and precision finishing, Mastercam Lathe gives you a variety of strategies to turn parts with greater efficiency and productivity.

Efficient programming, designed for modern manufacturing.

Mastercam Lathe delivers a set of easy-to-use, advanced programming tools, with greatly expanded options when paired with Mastercam Mill. Easy rough, finish, thread, groove, bore, and drill routines combine with C/Y-axis machining to cut any job. Dependable toolpath verification ensures your parts are done right the first time.

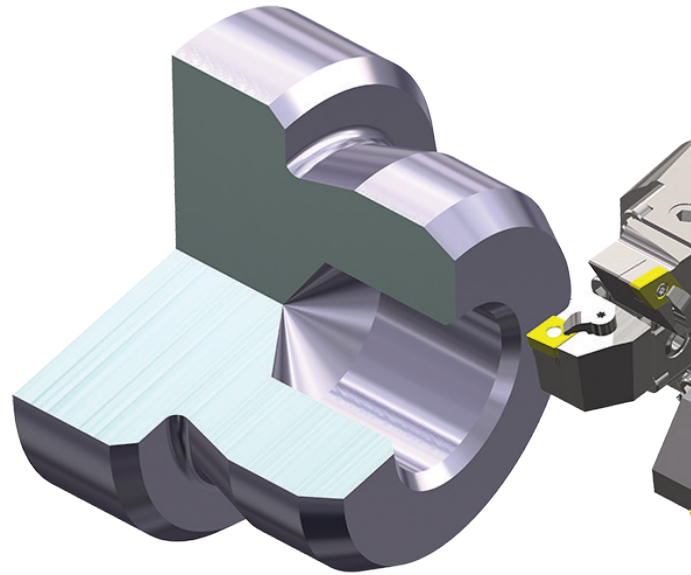

Fast, easy turning.

- Program in a few clicks with Quick Toolpaths.
- Complete threading including custom thread forms.
- Grooving with multiple depth cuts, peck motion, and full-radius plunge turning.
- Intelligent ID, OD, face roughing, and finishing.
- Full milling support available for machines with live tooling or C and Y axes.

Safe machine and cut control.

- Chuck, part, steady rest, and tailstock detection.
- Automatic gouge checking on the tool's front and back.
- Control chip breakage on difficult-to-machine materials.
- Full collet and solid jaw support.
- Expanded job setup, part transfer, and programming options on select lathes.

SWISS MACHINE SOLUTIONS

You no longer need a separate software package for Swiss machines — something programmers and machinists appreciate. Our Swiss machining solutions combine Mastercam Mill and Mastercam Lathe with specialized post processors. This configuration adds machine-specific controls inside the Mastercam interface, delivering accurate G-code for a wide variety of Swiss machines.

The solution provides customized choices directly within Mastercam for:

- Swiss-style bar feed stock advance.
- Machine-specific setup parameters.
- Swiss-style pick off / cut off strategies.
- Expandable custom machine options including lasers, high-frequency turning, high-pressure coolant, and more.

To learn more about Mastercam's Lathe solutions, visit mastercam.com/lathe.