



***Mastercam*® 2025**

WHAT'S NEW

Productivity | Performance | Progress

2025 TOP TEN FEATURES

Explore the new Mastercam features you have been waiting for! This brochure covers a few top features across the suite of Solutions that will enhance your productivity and profitability.

Visit [whatsnew.mastercam.com](https://www.whatsnew.mastercam.com) to see everything Mastercam's latest game-changing installment has to offer.

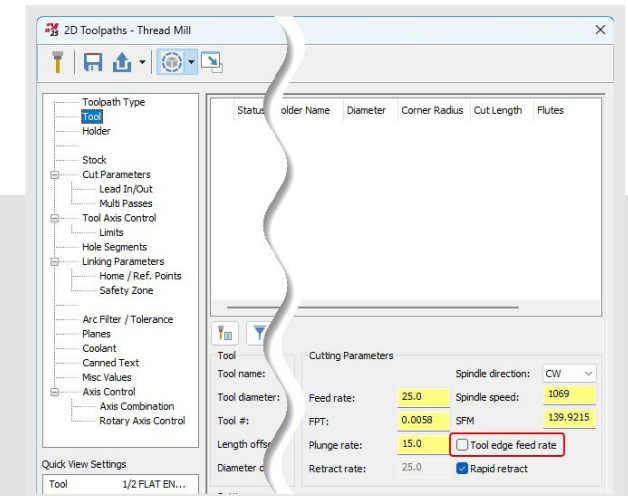
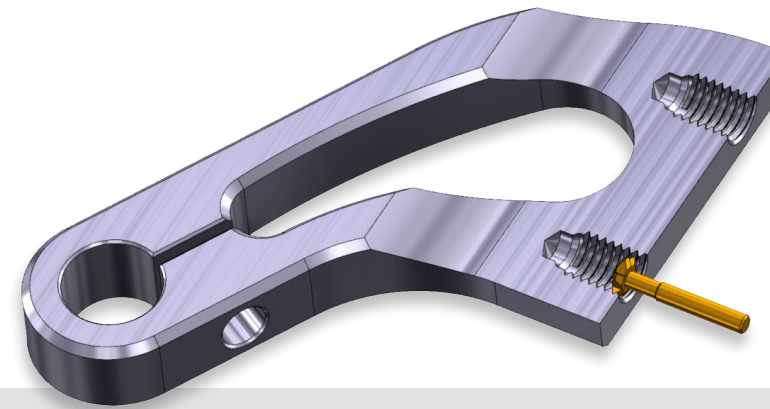

1

Deburr 3-Axis

Productivity | Add-On, 2D and 3D Mill, Router, Mill-Turn

The Deburr 3-Axis Add-On toolpath simplifies the deburring process through automatic edge detection and intuitive controls. It was created so that users can take advantage of the streamlined Deburr cycle in a 3-axis environment without a Multiaxis license. If you have a Multiaxis license, the simplified controls for 3-axis deburring will be familiar.

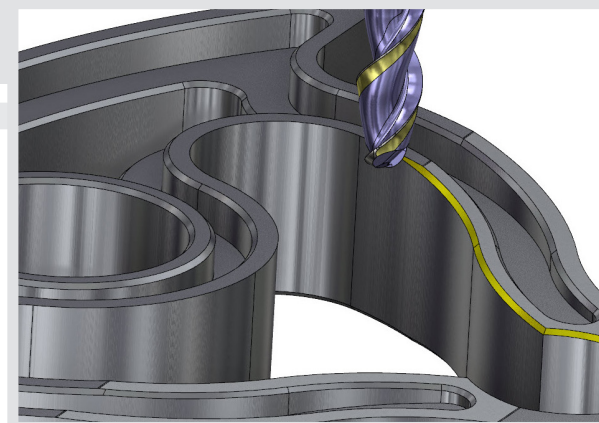
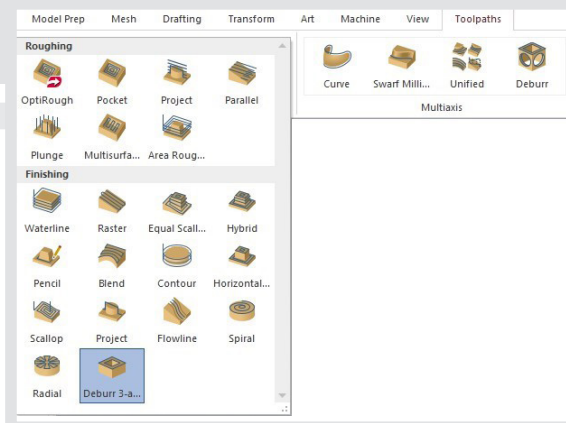

3

Thread Mill Enhancements

Performance | Mill, Router

Various Thread Mill Enhancements have been added in Mastercam 2025. A few of the top highlights are:

Speed/Feed Override for Lead In/Out

This feature provides better control during entry moves, which promotes better tool life and more accurate machining of threads.

Gradual Lead In/Out

This new lead in/out strategy provides the user with more control over the tool during engagement and disengagement for a Thread Mill operation. This strategy allows the user to engage the radial depth of a Thread Mill operation through a helical motion, which gradually engages the tool throughout a 180° arc sweep.

Throughout the arc sweep motion, the tool will engage 1/2 pitch deep before achieving full radial and axial thread depths.

Tool Edge Feed Rate

Use the new Tool Edge Feed Rate check box to calculate the feed rate based on the tool's tangential edge rather than on the centerline. When you activate Multi Passes with Tool Edge Feed Rate, Mastercam adjusts the feed rate for the different diameters needed for multiple passes.

This option also considers multiple diameters where you select holes with a range of diameters as input geometries and allows users to produce a more accurate feed rate based on the cutter diameter and the diameter of the hole being machined.

2

Finishing Passes for Dynamic Mill and Area Mill Toolpaths

Productivity | Mill 2D

Mastercam 2025 introduces the ability to add Finish Passes to 2D Dynamic Mill and Area Mill toolpaths. Use the new Finish Passes page to add high-speed finishing passes along the selected boundaries of the toolpath. After selecting the Finish Pass option, use the other parameters on this page to further define the finish pass, such as feed rate and spindle speed overrides. Use the stock-to-leave options on the Cut parameters page to ensure there is material for the finish passes.

In addition to the Finish Passes page, the new Lead In/Out page allows you to set specific lead in/out options for finish passes only.

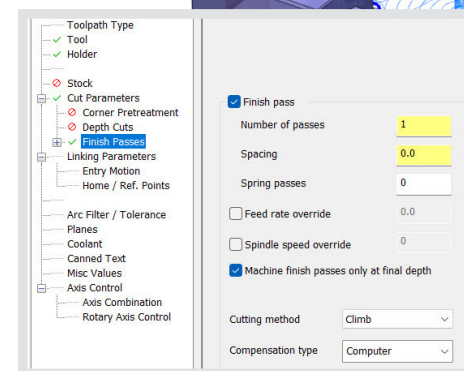
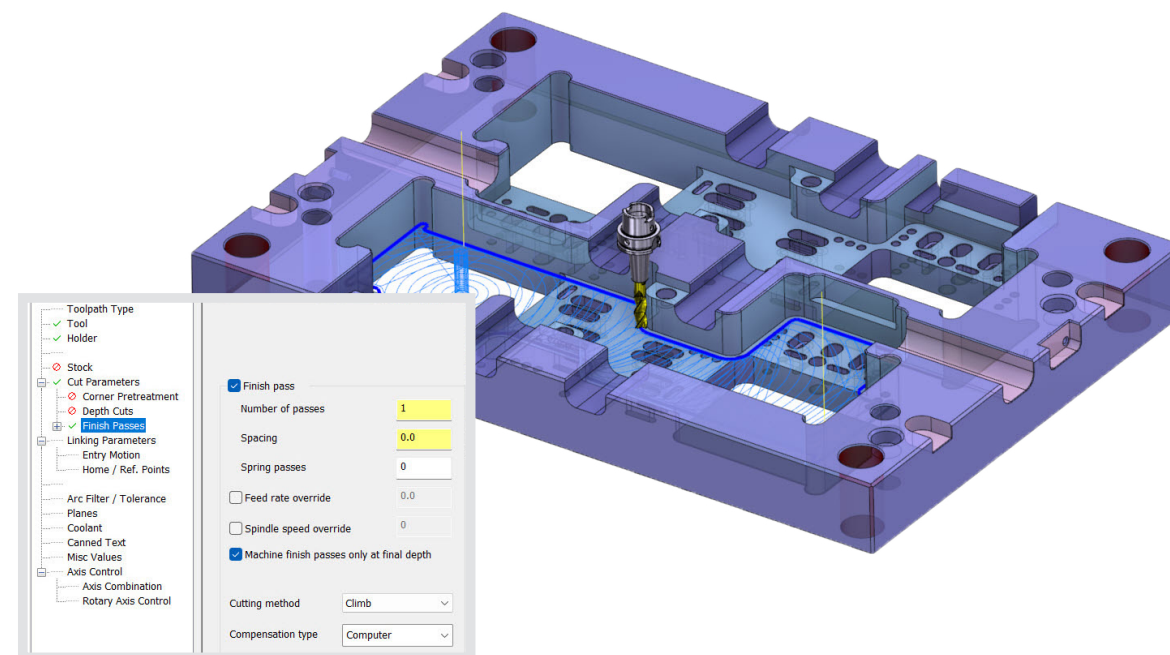

4

Solid Hole Selection

Productivity | Mill

Mastercam 2025 includes changes to the default selection behavior of the Solid Hole Selection and is therefore not optional. This will be useful for customers who use Hole Making and Process Hole toolpaths. The changes associated with this update create a more efficient, precise, and controllable hole selection. The Solid Hole Selection update encompasses many new behaviors for selecting holes.

Toolpath Hole Definition Changes

- Simplified selection rules.
- Multiple hole types are allowed in a single toolpath.
- Segment selections from the same hole are always joined together into a single feature.
- Selection from the solids history tree now adds all segments.
- Selection behaviors are now the same for both native Mastercam hole features and those related to imported neutral CAD formats.

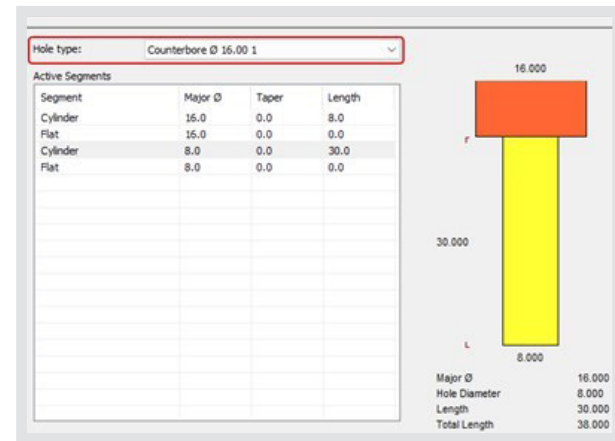

6

Y-Axis Turning Support in Mill-Turn

Progress | Mill-Turn

Mastercam 2025 introduces Mill-Turn support for Y-axis Turning. All turning toolpaths except custom thread and B-axis contour turning support Y-axis functionality.

Automatically create a set of planes that you can use to create your toolpath with the proper tool orientation and spindle origin. It also locks the B-axis to the 90-degree position.

In addition, the available approach and retract strategies have been enhanced to include Y-first strategies, along with the ability to designate tool assemblies as Y-axis compatible in the holder component page.

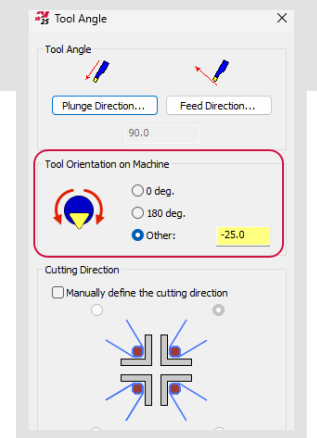
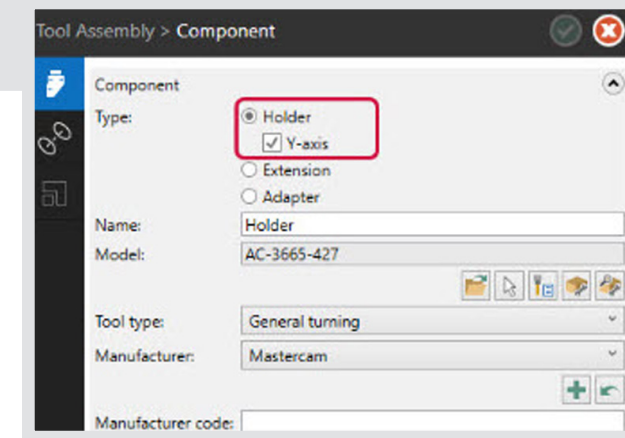

5

Safety Zone Improvements for Hole Making

Progress | Mill

In Mastercam 2025 the new Safety Zone now uses meshes for parametric shapes. Before the Safety Zone used a mesh for the Wrap Shape type only. This first phase of the updated Safety Zone is available for all Hole Making toolpaths including Process Hole. Along with an updated algorithm which results in the Safety Zone now being a post toolpath calculation, the following new parameters are now available:

- Linear Tolerance
- Blending Distance
- Smoothing Distance

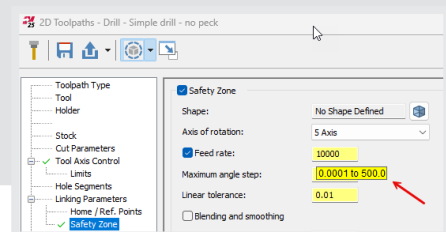
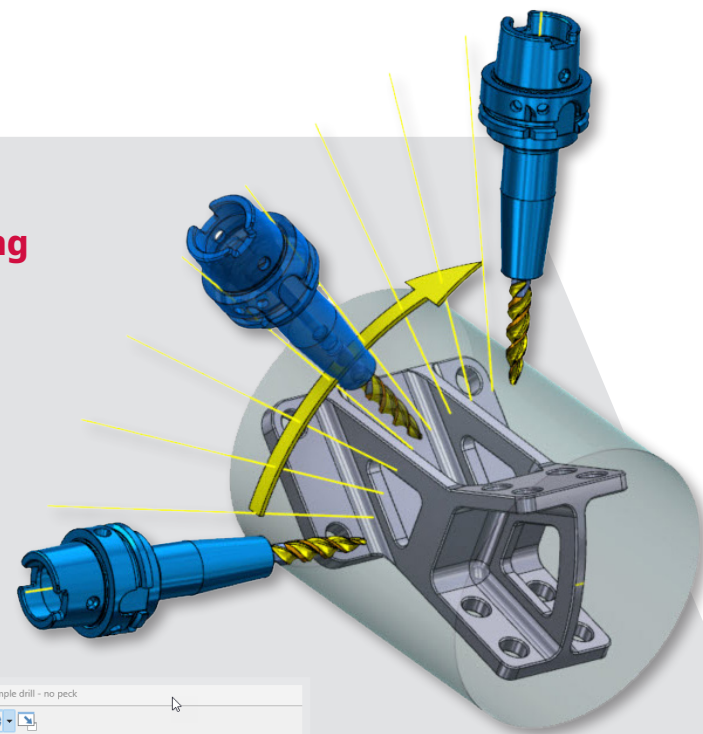

7

A-Axis Contour Turning in Mill-Turn

Progress | Mill-Turn

Mastercam 2025 introduces the new A-axis Contour Turning Toolpath. It complements the B-axis contour toolpath introduced in Mastercam 2023 and extends Mastercam's support for rotary contour turning. The new toolpath is very similar to the B-axis contour toolpath, except that it uses Y-axis tools. The ability to rotate the tool while in the cut lets Mastercam users reach difficult-to-machine areas while taking advantage of the latest advances in Y-axis tool technology.

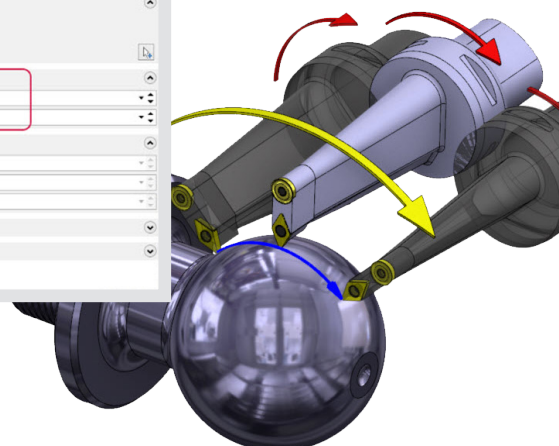
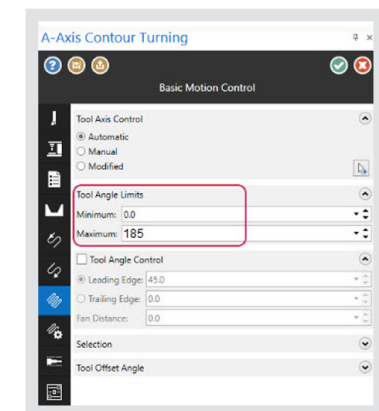

8

B-Axis Contour Turning Enhancements

Performance | Mill-Turn

Two new features have been added to the B-axis rotary contour toolpath in Mill-Turn. To start, you can now include splines in your chained geometry. In addition, new tool angle controls let you specify either a leading or trailing angle for the insert.

Tool Angle Control in B-Axis Contour Turning

Precise control of the tool axis during B-axis Contour is essential. It will enhance the toolpath creation process and will greatly improve the resulting machined finishes.

Spline Support for B-Axis Contour Turning

Converting splines into arcs and lines was an extra, tedious process. Driving a B-axis Contour toolpath on a spline will simplify and speed up the toolpath generation process.

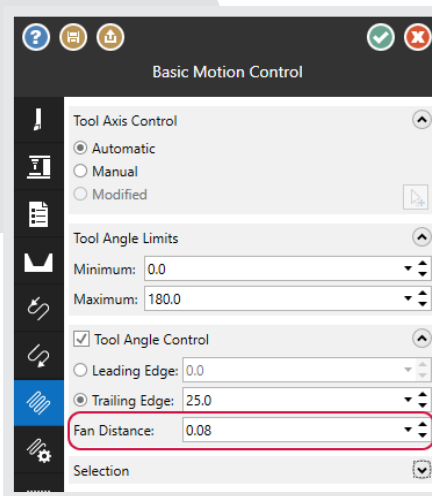
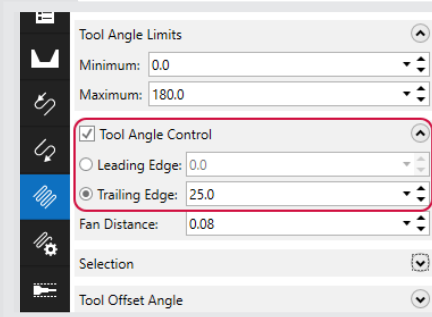

10

Machine Configuration Save/Load in Mill-Turn

Progress | Machine Systems, Mill-Turn

Mastercam 2025 introduces the ability for Mill-Turn platform users to store and reuse common machine setups, including work holding, tool holding, and tooling components. Mill-Turn users can save specific machine configurations to individual configuration files, then load them again to quickly use the same setup on additional parts.

Machine configurations can include any combination of work holding components, steady rests, and tool holding components. The tool holding components can include individual tools mounted in them.

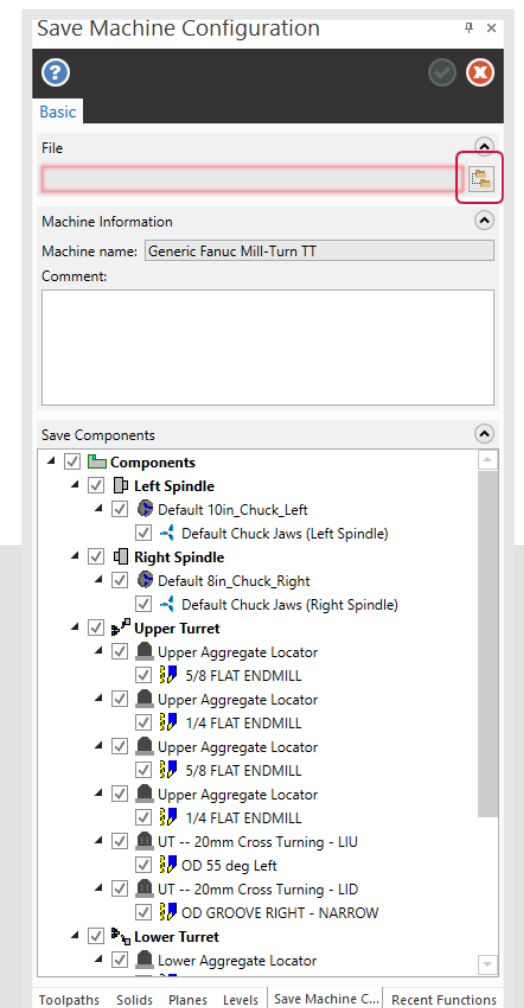
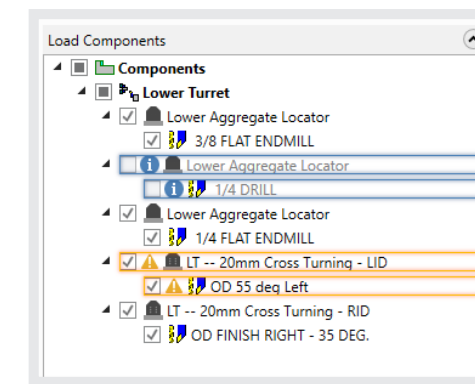

9

Analyze Deviation Function

Productivity | Design

Mastercam 2025 now includes Analyze Deviation. This function analyzes the differences between entities and applies a color coded "heat map" to the geometry, which display deviations within the graphics window. Deviation analysis allows you to compare any combination of points, curves, surfaces, bodies, or faces.

Deviation Legend	
Deviation Range	Color
0.240004 -> 0.300005	Red
0.180003 -> 0.240004	Orange
0.120002 -> 0.180003	Yellow
0.060001 -> 0.120002	Light Green
-0.082717 -> 0.060001	Green
-0.165433 -> -0.082717	Cyan
-0.248150 -> -0.165433	Blue
-0.330866 -> -0.248150	Dark Blue
-0.413583 -> -0.330866	Black

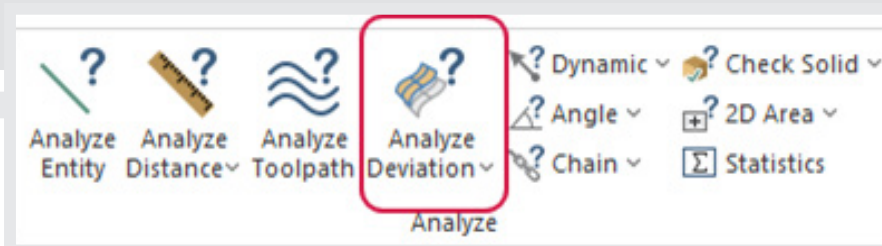
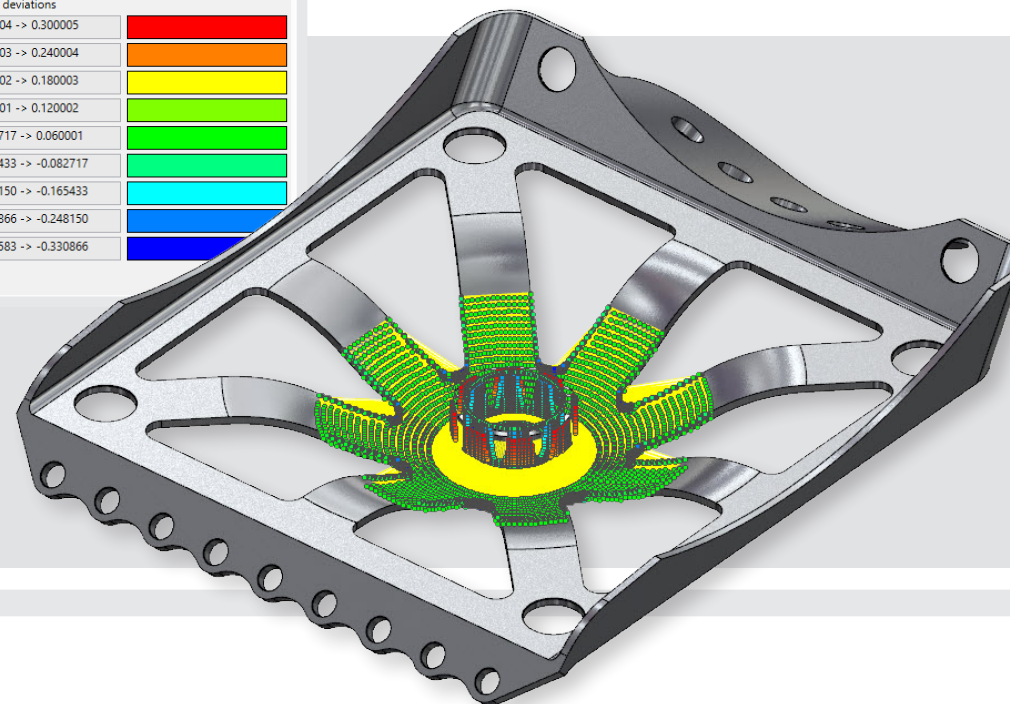

For more information on what's new in Mastercam 2025, visit [WHATSNOW.MASTERCAM.COM](https://www.mastercam.com/whatsnew)



THERE'S STILL MORE TO EXPLORE

Mastercam 2025 brings new features and enhancements focused on delivering speed and efficiency to your machining jobs. Here are some of the additional highlights we are offering for Milling, Turning, Machine Systems, and more.

Viewing Graphical Planes and Geometry Color with 2D and 3D Toolpaths

The graphical planes and geometry colors that were previously added to the hole-making and Multiaxis toolpaths are now included in the 2D and 3D Milling toolpaths.

Workholding for 3D and Model Chamfer Toolpaths

You can now use the workholding components defined in Machine Group Setup in your 3D high-speed and 2D Model Chamfer toolpaths.

New Job Setup Warning

Mill-Turn users who make changes to their Job Setup settings that result in changes to the lathe stock boundary — for example, changing the stick-out distance — will see a new warning message.

Adding Support Files to Machine Environments

Mill-Turn machine environments now include a Miscellaneous Files node.